

HUBERTY
& BREYNE

Louise COLLET

Pétrichor

23.05.2026
> 20.06.2026

PARIS | Chapon - 21

21 rue Chapon
Paris 3^e

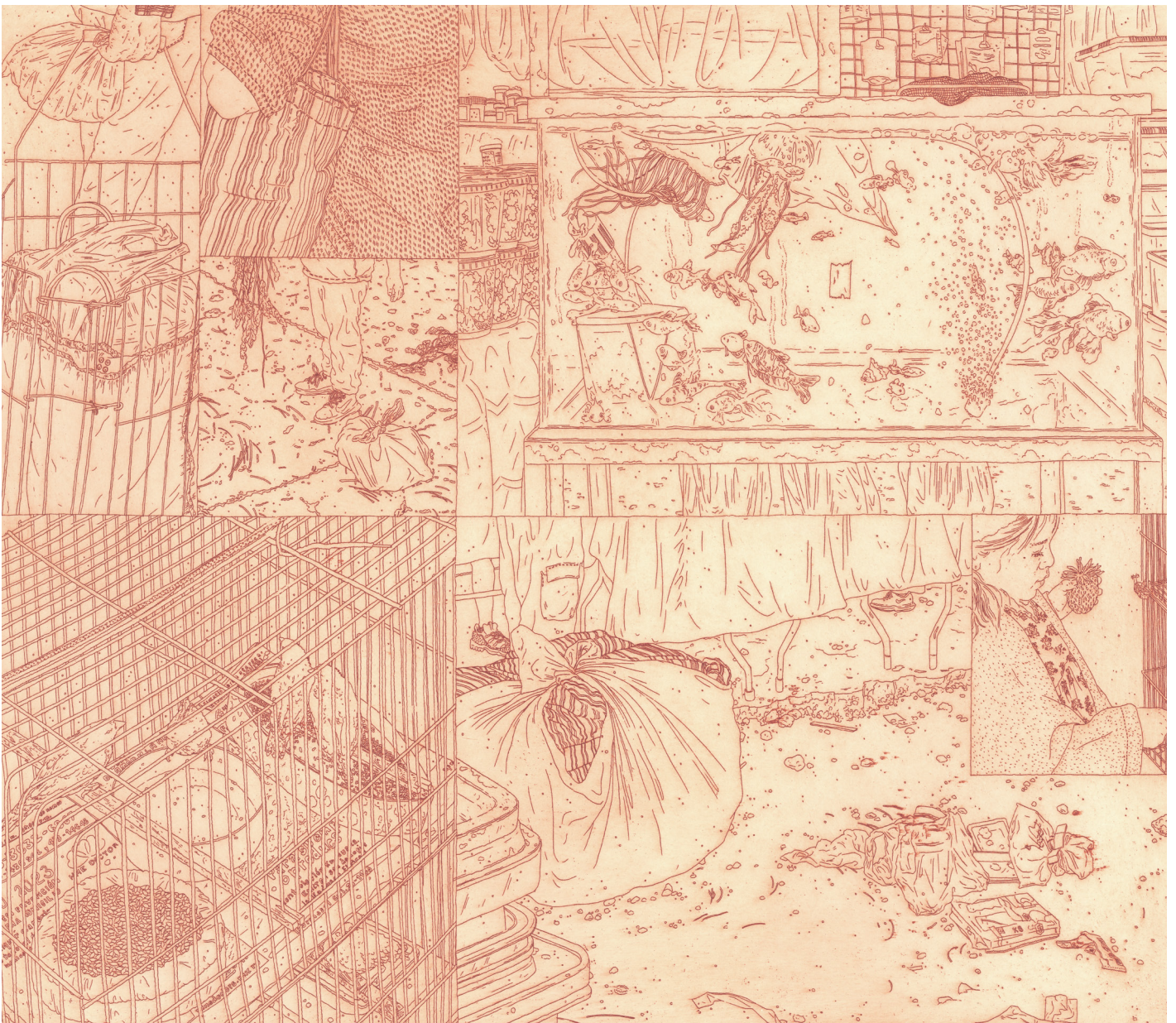

México mágico, Mercado Constitución 1, Zapopan, Mexico - 2025 - Etching on paper (printed by Atelier René Tazé) - 39,7 x 49 cm - Signed bottom right

With *Pétrichor*, Louise Collet continues a sensitive exploration of the connections between the natural world and the memory of landscapes. The exhibition's title, borrowed from the term describing the smell of earth after rain, introduces a reflection on lingering traces and aftereffects, in which the landscape appears less as a motif than as a state of unstable and shifting presence.



Carnet du Mexique, Comida casera Doña Lety - 2024 - Watercolor on paper - 24 x 33,2 cm

Trained at the École Boulle, ENSAD, and Kyoto City University of Arts, Louise Collet has developed a practice at the intersection of drawing, printmaking, and publishing. Her work is rooted in a sustained attention to forms of reality, understood as signs of a sensitive relationship to the world. This approach involves a slow and meticulous temporality, grounded in observation, repetition of gesture, and variation, where precision of line and sensitivity to material become part of the same visual language.

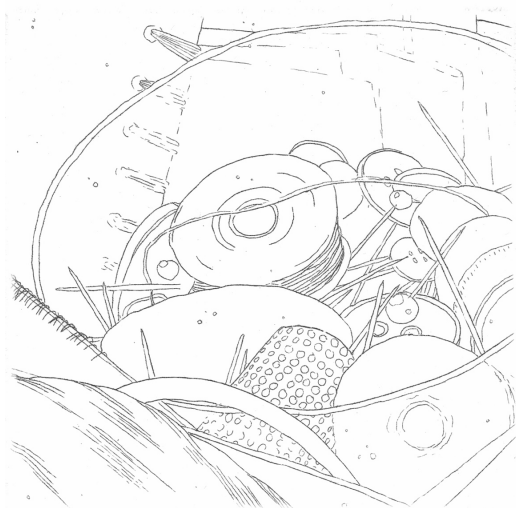

Des éclaircies - Boîte à couture - 2018
Etching on paper - 3,8 x 3,9 cm

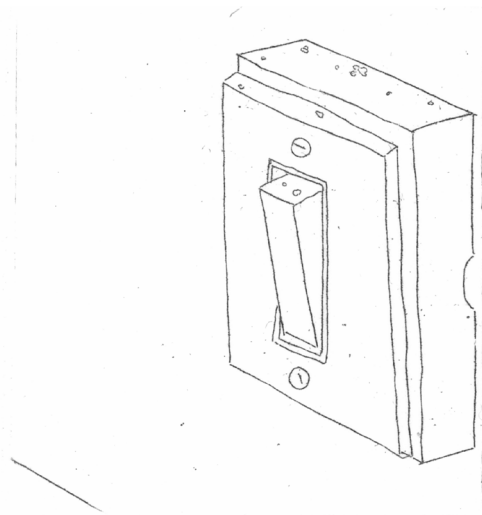

Des éclaircies - L'interrupteur de la petite pièce - 2018
Etching on paper - 3,8 x 3,9 cm



Des éclaircies - Un visage - 2018
Etching on paper - 3,8 x 3,9 cm

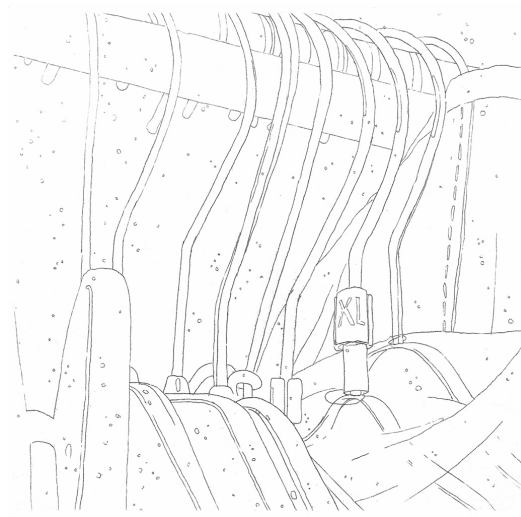

Des éclaircies - Le placard - 2018
Etching on paper - 3,8 x 3,9 cm

The exhibition, presented in our Paris | Chapon - 21 space, brings together a selection of etchings, ink works on paper, and watercolors from recent works and several publishing projects. These pieces notably extend publications such as *Un herbier* and *La forêt de Fontainebleau* devoted to George Sand (Reliefs Editions), *Les mains dans la terre* (Ouïe/Dire Editions), and *Des éclaircies* (Fidèle Editions). Together, these bodies of work highlight the importance of the book within the artist's practice, conceived as a space for experimentation inseparable from the practice of image-making.



Les mains dans la terre - Ink on paper - 43,7 x 52,7 cm

In this context, *Pétrichor* offers a cross-sectional reading of her recent work, attentive to the discreet forms of living things and their processes of transformation, between appearance and disappearance, memory and immediate perception.



Les mains dans la terre, 2 - 2023 - Gouache on paper - 5,5 x 9 cm

Louise COLLET

Pétrichor

OPENING

Friday 22 May 2026
from 6:00 p.m.
in the presence of the artist

EXHIBITION

From Saturday 23 May
to Saturday 20 June 2026

PARIS | Chapon - 21

21 rue Chapon, 75003 Paris
Wednesday > Friday 1:30 p.m. - 7 p.m.
Saturday 12 p.m. - 7 p.m.

CONTACT

Justine SENNEPIN
T. +33 (0)1 71 32 51 98
justine@hubertybreyne.com

HD visuals available on request

© 2026 - Louise COLLET

HUBERTY & BREYNE

Huberty & Breyne is a contemporary art gallery specializing in comic books, founded in 1989 and now run by Alain Huberty and Marie-Caroline Bronzini. With locations in Brussels and Paris, it promotes established and emerging artists linked to or inspired by the 9th art.

Its exhibitions of original comic strips, paintings, and sculptures support contemporary creation in all its diversity and the blending of disciplines. An international reference in the field of the ninth art, it offers collectors a rigorous selection of works by classic and promising artists.

The gallery takes part in major art market events, participating in international fairs such as Brafa, Art Paris, and Drawing Now. It has a 1,000 m² space in Brussels, on Place du Châtelain, and two spaces in Paris, on Avenue Matignon and Rue Chapon.

In addition to his gallery activities, Alain Huberty is a comic book expert for auction houses.

BRUSSELS | Châtelain

33 place du Châtelain
1050 Brussels
+32 (0)2 893 90 30

Wednesday > Saturday
11.00 am – 7.00 pm

PARIS | Matignon

36 avenue Matignon
75008 Paris
+33 (0)1 40 28 04 71

Tuesday > Saturday
11.00 am – 7.00 pm

PARIS | Chapon

19 rue Chapon
75003 Paris
+33 (0)1 71 32 51 98

Wednesday > Friday
1.30 pm - 7.00 pm
Saturday
12 pm - 7.00 pm

contact@hubertybreyne.com
hubertybreyne.com